

УДК 512.64 + 514.12У

LASER GUIDANCE SYSTEMS BASED ON THREE-DIMENSIONAL HOLOGRAPHIC OPTICAL ELEMENTS

Akhmerov O. Yu.

Ph.D.,

Zhukov S.O.

Savasteeva O.M.

Tyurin O.V.

Odessa National University, Odessa, Dvoryanska, 2, 65082

Abstract. The technology of creation of three-dimensional holographic optical elements with controlled characteristics on the basis of heterophase microsystem "CaF₂ core – AgBr shell", alkaline halide crystals (AHC) and chalcogenide glassy semiconductors (CGS) is proposed. We also consider the applications of holographic optical elements based on three-dimensional transmitting diffraction structures for solving some practical problems.

Key words: Core-shell, microsystem, sensitization, photochemical transformation, hologram.

Introduction.

The emergence and improvement of holographic methods, as well as technical equipment for their implementation revived interest in light diffraction in three-dimensional periodic structures. This is due to the fact that holographic methods allow to create a relatively simple and affordable technology for the manufacture of three-dimensional diffraction structures for both transmitted and reflected electromagnetic radiation of the visible range of the spectrum. Previously, light diffraction was used only in two-dimensional periodic diffraction structures, the manufacture of which was possible by other methods (chemical, photographic, mechanical, etc.). Diffraction in three-dimensional periodic structures for transmitted radiation has become widespread only for X-rays, for which a crystal lattice of various substances could be used as a three-dimensional periodic structure. The use of diffraction of electromagnetic radiation of the visible spectrum on holographic three-dimensional structures (holograms) for practical purposes allows to create optical elements and optoelectronic devices of a fundamentally new class based on them, which have the widest range of applications.

Results.

3D transmission diffraction structures of the optical range, which are a combination of the simplest 3D transmission holographic diffraction gratings (3D

THDG), in comparison with a 2D diffraction grating, provided them with the acquisition of the following distinctive properties during light diffraction [1]:

– during the diffraction of monochromatic light on a 3D THDG, only one diffraction maximum is observed and, therefore, only two rays are formed as a result of diffraction – the passing I_R is diffracted I_S (Fig.1).

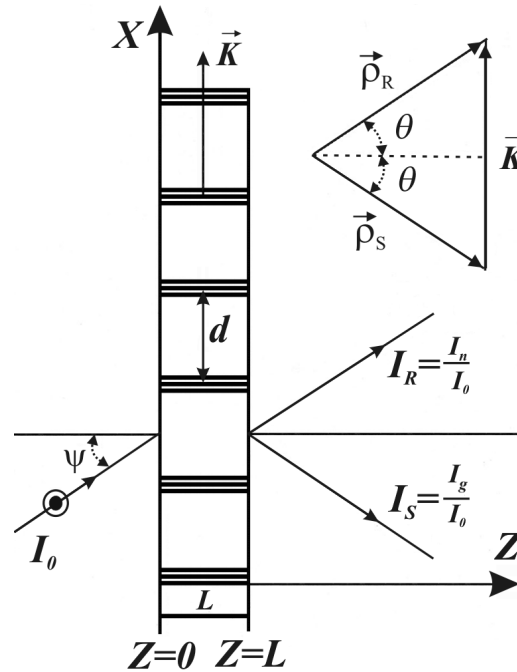

Fig. 1. Diffraction of monochromatic light on 3D THDG.

– when the angle of incidence ψ of the I_0 ray on the 3D THDG changes, energy exchange occurs between the transmitted and diffracted rays and their intensities change, while the spatial direction of propagation of these rays is preserved. Energy transfer between beams can reach 100%. Curves of angular dependence of intensities passed I_R and diffracted I_S rays are completely determined by the parameters of 3D THDG and for 3D THDG with 100% diffraction efficiency are shown in Fig. 2.

– when diffraction of a white collimated beam of light falling at a certain angle on a 3D THDG, diffraction is observed only for light of a certain wavelength λ , which satisfies the Bragg condition $\lambda = 2d \sin \theta$, where d is the period of the grating, θ (Bragg angle) is the angle of incidence of the collimated light beam on the grating.

The presence of such specific properties in 3D THDGs allows them to be used

as holographic optical elements (HOEs) for various optoelectronic devices that have unique properties unattainable by other methods [2-3].

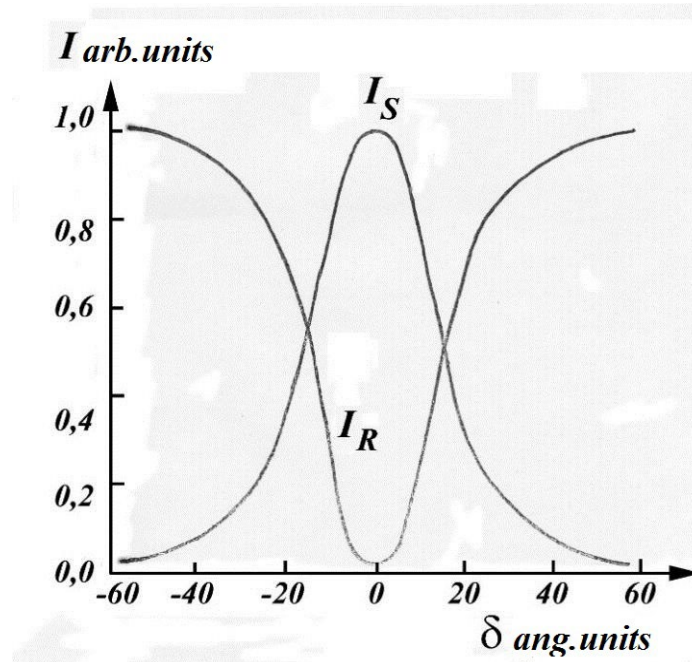

Fig. 2. Angular dependences of I_S and I_R for gratings with 100% diffraction efficiency.

Let's consider the laser guidance systems proposed by us, the basis of which are optoelectronic devices for measuring angular displacements based on 3D transmissive diffraction structures of the optical range, which are a combination of the simplest 3D THDGs.

Optoelectronic devices for measuring angular movements along one coordinate.

Currently, high-precision remote measurements of angular displacements are mainly carried out with the help of optical-electronic angle measuring systems, which are based on the autocollimation method of measurement [4].

The essence of this method is that a light stream with a known orientation is sent and then deflected by the object to the desired angle, thanks to which this stream acquires the necessary information. In the autocollimation method for remote measurement of the angular position of objects from all parameters of the light flux, only the property of rectilinear propagation of the light flux in a homogeneous medium is used and the change of this direction of propagation in accordance with

the modulating influence of the object under study. The results of measurements performed with the help of such optical-electronic angle-measuring systems largely depend on the parameters of the photoelectric converter (position-sensitive sensor) [5] - a device that measures linear coordinates in the image plane of optical-electronic angle-measuring systems and its conversion into electric current (voltage), which have reached their accuracy limit of 1 *arcsec* [6] and, at present, no longer lead to a further noticeable improvement in the quality of optical-electronic angle measuring systems.

In this regard, it is promising to use other measurement methods that would improve measurement accuracy. This can be a method of measuring the angular displacement of objects, based on a change in the intensity of the information light signal in accordance with the modeling effect of the object under study, and not on a change in the spatial position of the light beam, as in the autocollimation method.

In this case, there is no need to use position-sensitive sensors to implement the measuring functions of optical-electronic angle measuring systems - it is enough to use only photoreceptors for photoelectric conversion of signals, since the effect of information conversion for this method depends only on the intensity of the incoming light flux.

Nowadays, there are various photo receivers that allow you to implement almost all the requirements for modern optical-electronic angle measuring systems in terms of accuracy, speed and other technical design parameters.

It is possible to implement such a method if a 3D THDG is used as an optical element, since the 3D THDG itself has the property that when the angle of incidence of the object beam on the 3D THDG changes (due to, for example, the rotation of the controlled object), the intensity of the passing beam changes I_R and diffracted I_S rays without changing their spatial arrangement (Fig. 2).

Direct use of dependencies I_R or I_S for determining the angular displacement of the object, based on the change in intensity of the passing or diffracted beam, is associated with some disadvantages. If, for example, the maximum value of the intensity of the diffracted beam (Fig. 2) is chosen as the zero reference, then this

corresponds to the extremum of the dependence of $I_S(\delta)$ and, therefore, in this area, the measurements are characterized by a large nonlinearity and are unclear with respect to the direction of displacement of the object to the right or to the left.

These shortcomings can be eliminated if the difference in intensities is used for measurements transmitted and diffracted rays $\Delta I = I_R - I_S$. For a pure phase grating with a diffraction efficiency of 100%, this dependence is presented in Fig. 3.

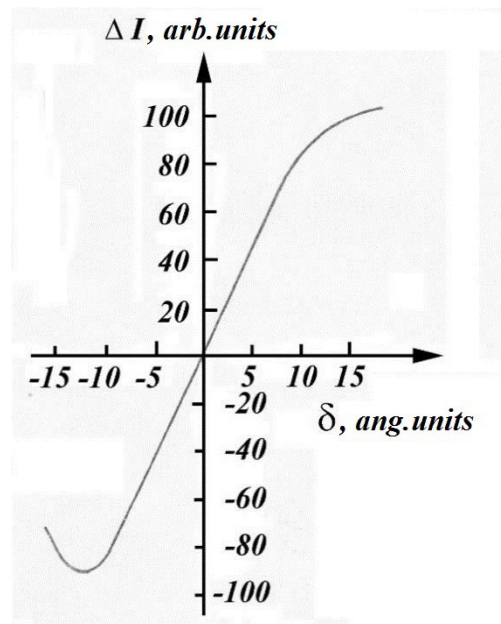

Fig. 3. Angular dependence $\Delta I = I_R - I_S$.

(The angular dependences of I_R and I_S are shown in Fig. 2).

I_S and I_R are the same is taken as the zero reference, and the difference is $\Delta I=0$ (the level of intersection of the curves I_S and I_R in Fig.2). As it is possible to see from Fig. 3 the dependence of $\Delta I(\delta)$ near $\Delta I=0$ is linear in nature, and the direction of angular displacement to the right or left differs from the sign of the output signal ΔI .

The largest linear range and symmetrical limits of measurement in this case are achieved at the intersection of the curves of the angular dependence of I_S and I_R at the level of 0.5 of the maximum value of I_S . This condition is fulfilled only for gratings with a diffraction efficiency of 100%, with a lower diffraction efficiency of the intersection of the curves of the dependences I_S and I_R are not symmetrical with

respect to the maximum values (Fig.4) and the linear range of measurements decreases.

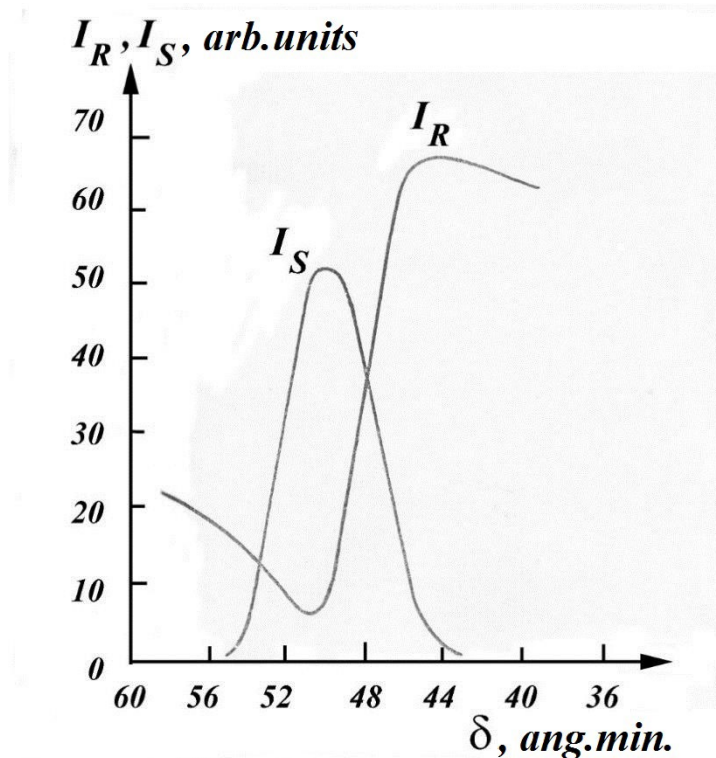

Fig. 4. Angular dependences of I_S and I_R for a 3D transmission holographic diffraction grating with a diffraction efficiency of 35%.

However, by changing the intensity of the beam or the sensitivity of the photodetector, it is quite simple to shift the curve parallel to the bottom and ensure the intersection of the curves of I_S and I_R at the level of 0.5 of the maximum value of I_S .

Preservation of all the properties of the differential measurement method for 3D THDG is also possible if for angular displacement measurements, GOE is used, which is a combination of two 3D THDG, the angular selectivity contours of which intersect at the level of 0.5 of the maximum value of the diffracting beams, and are recorded in one and the same region of the light-sensitive environment.

The production of such a GOE takes place on the device, the schematic diagram of which is shown in Fig.5.

During the first exposure, the 3D light-sensitive medium (4) is illuminated by two plane waves (22) and (23) falling from the angles β_1 and β_2 . At the same time,

the first 3D THDG is recorded. During the second exposure, the light-sensitive medium (4) is illuminated by two plane waves (23) and (24), which fall at the angles β_2 and $-\beta_1$, and the second 3D THDG is recorded.

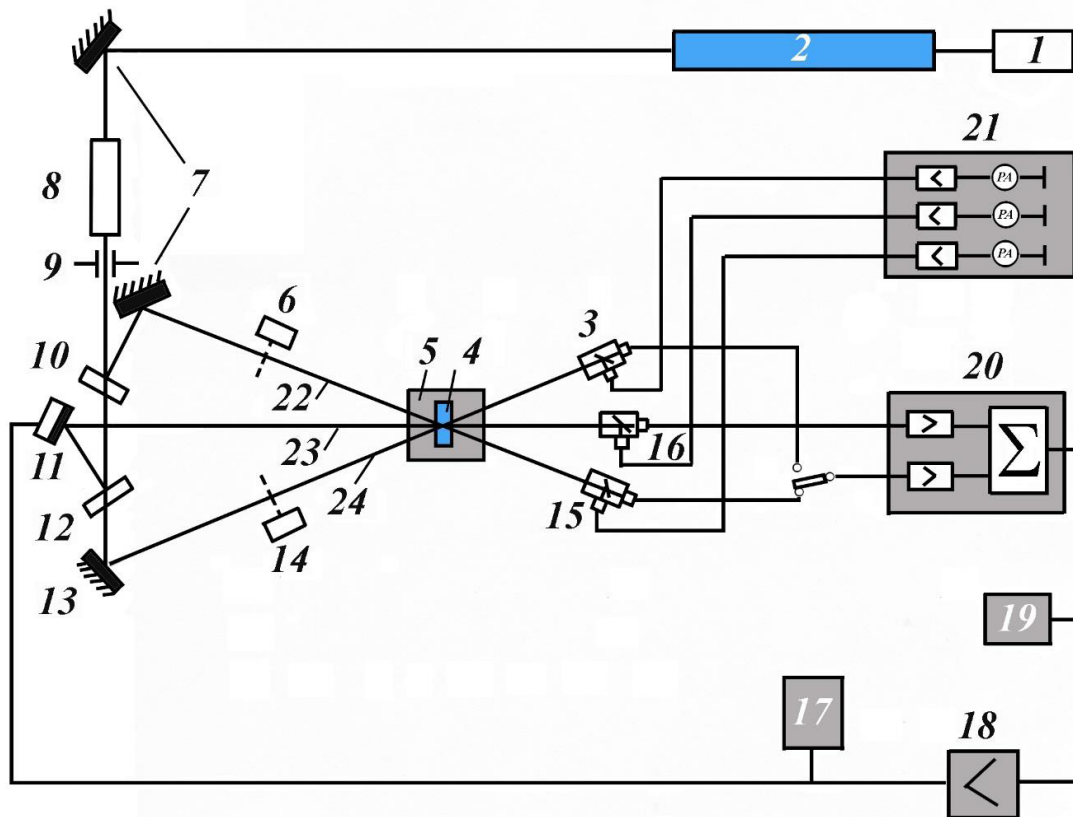

Fig. 5. Schematic diagram of the device for recording a holographic optical element:

1 - laser power supply unit; 2 – laser; 3, 15, 16 - photodiodes; 4 – 3D light-sensitive environment; 5 – oven-thermostat, which is installed on a rotary table; 6, 14 - close; 7, 13 - mirrors; 8 – beam expander; 9 – diaphragm; 10, 12 - light splitter ; 11 – mirror fixed on piezoceramics ; 17, 19 - oscilloscopes; 18, 20, 21 - electronic blocks of the stabilization system and determination of the holographic characteristics of sublattices; 22, 23, 24 are beams recording 3D transmissive holographic diffraction gratings.

In this case difference in intensities can be used as an information signal diffracted beams on the corresponding 3D transmission holographic diffraction gratings.

The optical and electrical scheme of such a device is presented in Fig. 6.

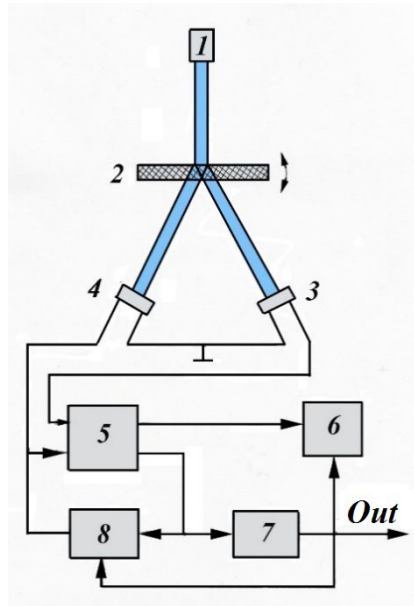

Fig.6. Schematic diagram of the angle measuring device:

1 - emitter; 2 – GOE, made in the form of a combination of two 3D THDG, with the same periods and angles of inclination of the stroke planes (Fig.7, a); 3, 4 - photo receivers; 5 – differential amplifier; 6 – display node; 7 – three-stable comparator; 8 - gain control.

The device works as follows. The light flux from the emitter (1) falls on the GOE (2), the angular arrangement of the plane of which relative to the optical axis of the light flux is the object of measurement. Two diffracted beams that came out of the GOE are registered by photodetectors (3) and (4), which are switched on according to the differential circuit. The signal coming from the differential amplifier (5) enters the display node (6) and three-stable comparator (7) for communication with the gain regulator (8), which is included in the feedback circuit of the differential amplifier to adjust the sensitivity of the device. In sighting mode with a range of 3 *arc.min.* sensitivity was 0.1 *arcsec* .

Fig. 7b shows a graphical view of the dependence of the intensities of the beam passing through I_R and the diffracted beams I_S and I_u on the angle of incidence of light ψ , which is normalized to the Bragg angle θ . From the analysis of the I_S and I_u graphs , it can be seen that when the angle of incidence changes due to the energy

exchange between the passing and diffracted beams, there is a change in I_S and I_u with opposite signs, which are fixed by photodetectors installed on the optical axes of the diffracted beams and connected to the input differential amplifier. At the same time, the influence of additive interference caused by, for example, background lighting is minimized. The level of intersection of the curves I_S and I_u is determined by the values of the intensities at normal incidence of radiation. Figure 8 shows the dependence $I\Delta = I_S - I_u$ from the angle of light incidence normalized to the Bragg angle on the GOE at different parameters ξ_N , which characterizes the property of the GOE. The slope and width of the quasi-linear measurement section depends on the parameter ξ_N .

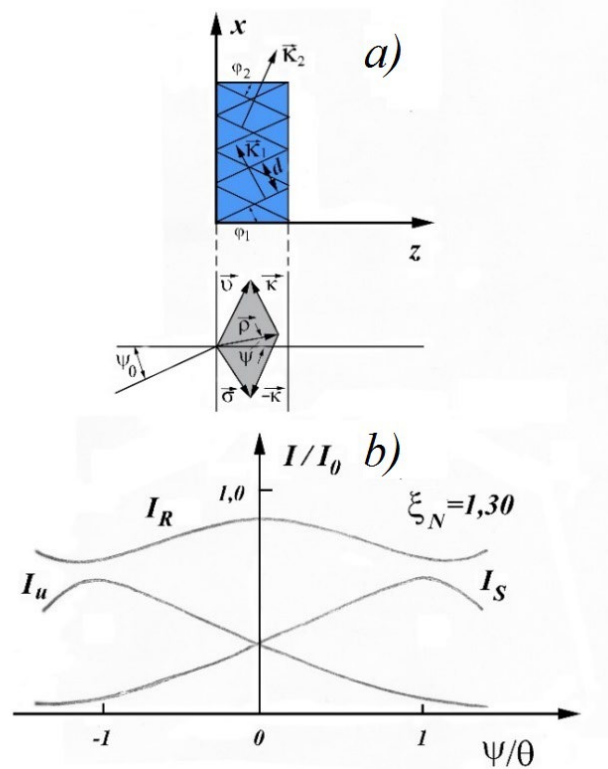

Fig.7,

a) vector diagram explaining the diffraction of light on a combination of two 3D THDGs ; b) dependence of the intensities of the passing beam, I_R and the diffracted beams I_S and I_u , on the angle of light incidence ψ , which is normalized to the Bragg angle θ .

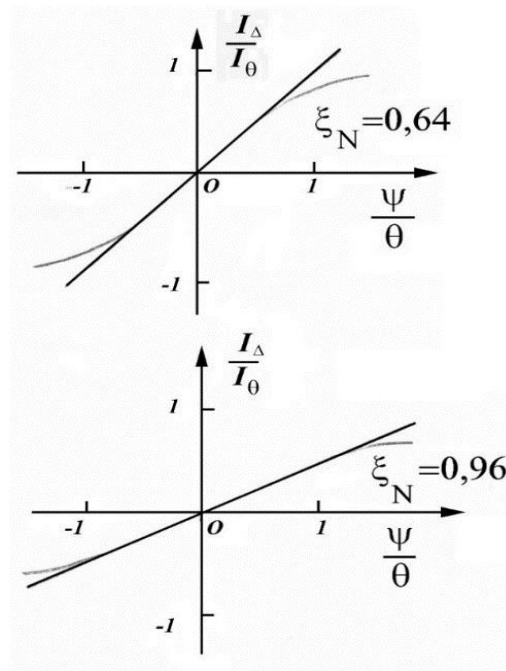

Fig. 8. Dependence on the angle of incidence of light ψ normalized to the Bragg angle θ on the GOE at different parameters ξ_N .

Optoelectronic devices for imaging in two coordinates.

To measure angular displacements simultaneously along two coordinates, it is necessary that four 3D THDGs were recorded in the volume of the light-sensitive medium, each pair of which provides independent measurement of angular displacement along its coordinate. The method of recording such a holographic optical element was reduced to the following:

1. The 3D light-sensitive medium (4) (Fig. 5) was oriented so that the beam (23) fell along the normal to its surface. Then the light-sensitive medium was rotated by 4 - 6 *arcmin* in the direction of the beam (24). In this position, beams (22) and (23) recorded the first 3D THDG.

2. After recording the first 3D THDG, the light-sensitive medium was rotated by 8 - 12 *arcmin* around an axis perpendicular to the plane of incidence of the rays in the direction of ray (22), and in this direction the rays (23), (24) recorded the second 3D THDG.

3. The light-sensitive medium was rotated by 90^0 around an axis lying in the plane of incidence of the rays and coinciding with the direction of the beam (23).

After that, the third 3D THDG was recorded.

4. The last, fourth 3D THDG was recorded by rays (22) and (23) after the light-sensitive medium after the end of recording the third 3D THDG, which turned in the direction of beam (24) by 8 – 12 *arc.min* around an axis perpendicular to the plane of incidence of the rays.

When such a diffraction structure is illuminated by a monochromatic beam of light in the direction of the beam (23), as a result of diffraction, four diffracted light beams are formed, located in pairs in mutually perpendicular planes (Fig. 9). The intensity of the diffracted rays I_1 , I_2 , I_3 and I_4 depends on the orientation of the GOE relative to the incident light beam. When turning the GOE around the O axis (Fig. 9), the intensities of rays I_3 and I_4 remain unchanged, and only the intensity of rays I_1 and I_2 changes. On the contrary, when the GOE is rotated around the Ox axis, the intensities of rays I_1 and I_2 remain unchanged, and only the intensity of rays I_3 and I_4 changes. Angular dependences of intensities I_1 , I_2 and I_3 , I_4 when rotating the GOE around the axes Ox and Oy , respectively, are shown in Fig.10.

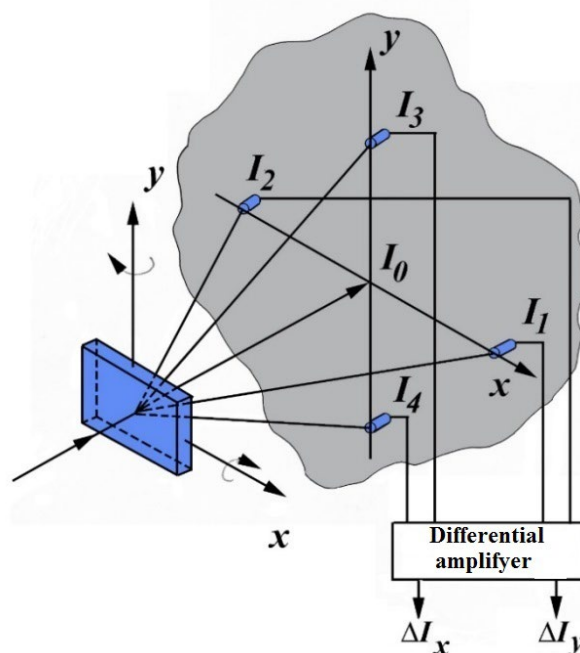

Fig. 9. Diffraction of light on GOE (a medium in which four 3D THDGs are recorded): I_0 – a beam of light passing through; I_1 , I_2 , I_3 and I_4 are light beams diffracted by 1, 2, 3 and 4 3D THDG, respectively.

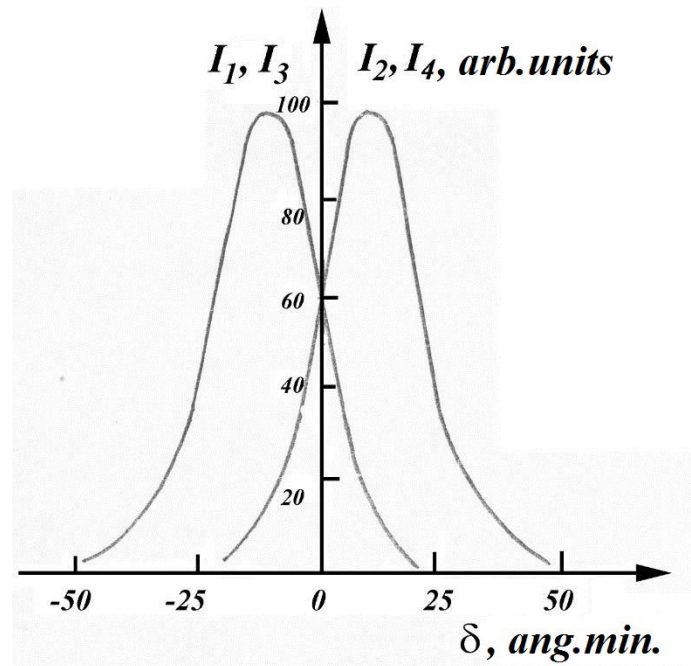

Fig. 10. Angular dependence of the intensity of the diffracted beams on the first I_1 , the second I_2 , the third I_3 and the fourth I_4 3D THDG: I_1, I_2 – when rotating the GOE relative to the Oy ; I_3, I_4 are relative to the Ox axis .

The level of intersection of the angular selectivity curves I_1, I_2, I_3 and I_4 is determined by the value of the intensities I_1, I_2, I_3 and I_4 , with normal radiation incidence on the GOE, the position of the GOE corresponds to the zero reference. When the angle of incidence changes, as can be seen from Fig.10, as a result of the energy exchange between the diffracted beams, there is a redistribution of intensities with corresponding signs.

Thus, the diffraction of light on the GOE has such properties that each pair of 3D THDG can provide independent measurements of the angular displacement of objects along the corresponding coordinate by changing the intensity of the beams diffracted on them. For this, it is only necessary to install photodetectors on the path of each of the diffracted beams (Fig. 9), respectively, switched on in pairs according to the differential scheme. Then the dependence of the values of the output signal of the differential amplifier $\Delta I_y = I_1 - I_2$ and $\Delta I_x = I_3 - I_4$, on the angle of rotation of the GOE will be determined by the properties of the diffraction structure, which is shown in Fig. 11.

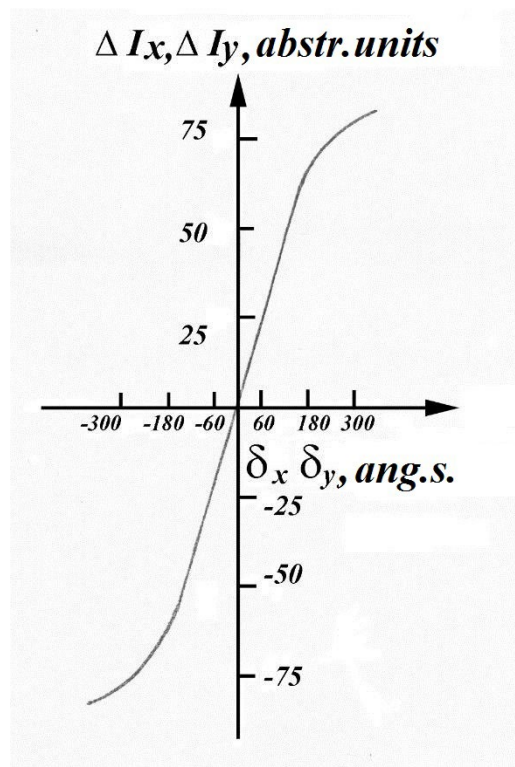

Fig. 11. Dependence of the output values of the signal of the differential amplifier ΔI_y and ΔI_x on the angle of rotation of the GOE.

δ_x – the angle of rotation of the GOE relative to the Oy axis, δ_y – rotation angle relative to the Ox axis.

To use the GOE in the sighting (guidance) system, the device must be equipped with an inverse link that provides compensation, which can be caused by any factors of rotation of the object from the indicated direction.

The visa process by the proposed method is as follows. The device, which is used for sighting in a given direction, is connected to the GOE. A laser beam of light that falls on the GOE determines the direction of vision, passing through it and forming five beams – four diffracted and one transmitted. The radiation passing through the diffraction structure coincides in the direction of propagation with the laser beam falling on the GOE, and does not participate in the operation of the device and continues to provide the imaging direction. The intensities of the diffracted rays are recorded by the sensors and fed to the input of the differential amplifier. Output signals from the amplifier, which correspond to the difference $\Delta I_y = I_1 - I_2$ and $\Delta I_x = I_3$

$-I_4$, are fed to the executive mechanism, which rotates the device depending on the polarity of the signal, and is fed ("+ -" or "- +») in one direction or another around the Oy or Ox axis. In the case when $I_1=I_2=I_3=I_4$, no voltage is applied to the executive mechanism, there is no rotation - the device registers the given direction. If the imaging object (or imaging device) is turned, then as a result of redistribution of energy between rays I_1, I_2, I_3 and I_4 at the output of the amplifier, signals ΔI_x and ΔI_y arise, which force the executive mechanism to rotate the sighting device around the axes Oy or Ox until the intensities of the rays reach equality, and the signals returning the device are compensated, and the device returns to the initial state ($\Delta I_x = \Delta I_y = 0$).

The imaging process with the help of such a GOE can also be carried out by laser light scattered from the imaging object, which is relatively easy to do if the source of scattered light from the imaging object can be considered as a point source. In this case, the GOE is placed at the focus of the converging lens (Fig. 12), and the device registers the specified viewing direction ($\Delta I_x = \Delta I_y = 0$), when the point source of light scattered from the imaging object lies on the main optical axis of the lens.

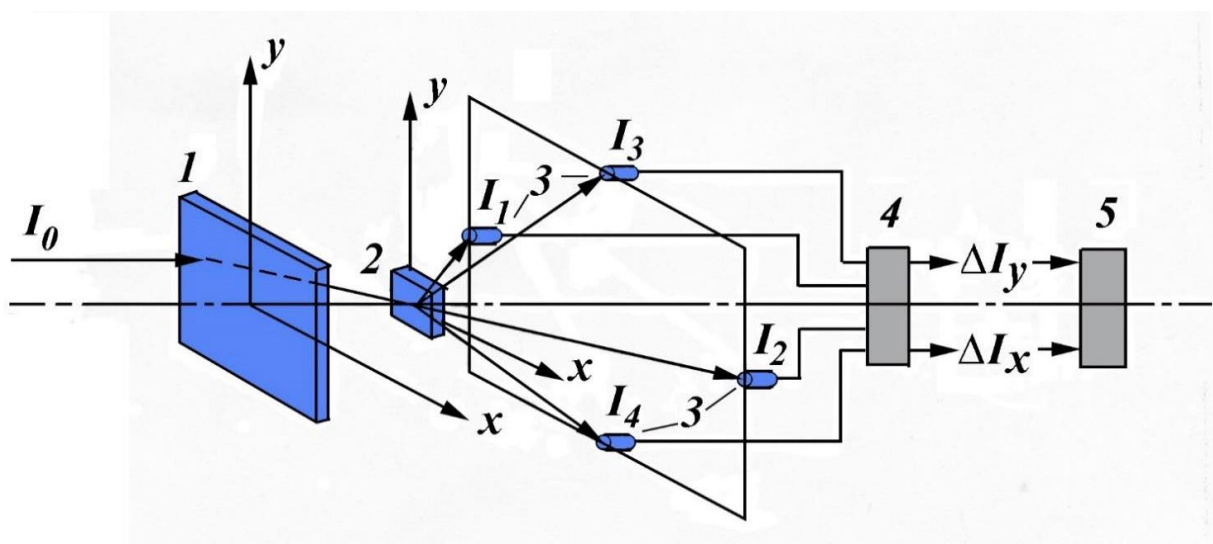

Fig.12. Schematic diagram of a two-coordinate sensor of the position of a point light source based on GOE:

1 - holographic lens; 2 - GOE, consisting of 4 3D THDG; 3 - photo receivers; 4 - differential amplifier; 5 - indicator device.

When the point source of scattered light is deviated from the main optical axis of the lens as a result of the displacement of the sighting object (or sighting device), signals ΔI_x and ΔI_y appear at the output of the amplifier, which, through the executive mechanism, return the device to the initial state of registration of the specified direction of sighting to the point a diffuse light source when it is located on the main optical axis of the lens. The focal length of the holographic lens determines the range and accuracy of the measurement.

Thus, as can be seen from the obtained results, the use of angular selective properties of 3D THDG allows to create fundamentally new optoelectronic devices based on them, which are characterized by simplicity of design, high measurement accuracy and wide functionality. It should also be noted that sharper angular selectivity of the GOE and, accordingly, higher accuracy of measurements can be achieved when using speckle wave to record the GOE. In addition, such GOEs also have a number of new properties and, first of all, translational selectivity, which is associated with the inconsistency of the recorded and read speckle structure. But this is the subject of further research.

Literature

1. Kogelnik H. Coupled wave theory for thick hologram gratings // Bell . Syst . Techn . J. –1969, –Vol. 48, –No. 9, –P. 2909. 2947.
2. Bekshaev A., Sviridova S., Popov A., Rimashevski A., Tyurin A. Optical vortex generation by volume holographic elements with embedded phase singularity: Effects of misalignments // Ukr.J.Phys. Opt. – 2013 – Volume 14 – Issue 4 – P.171–186.
3. O.V. Tyurin , Zhukov S.O., Akhmerov O.Yu. Creation, properties and application of three-dimensional holographic optical elements // Odesa: Odesa National University named after I.I. Mechnikov, 2023. 337 p.
4. Kapychyn I. I. Optical-electronic angle measuring systems. - Kyiv : Technika, 1986. 144 p.
5. Optoelectronic digital sensor of the angle of rotation / P. F. Oleksenko, Yu. V.

Ushenin , Yu. V. Kolomzarov , Yu. Ya. Tsirkunov , L. D. Yatsko , G. V. Brodovyi ,
V. P. Ishchuk // Science and innovation . 2007. Vol. 3. No.6. P.4 – 12.

6. A. G. Dodonov, V. G. Putyanin. Terrestrial optical, optical-electronic and
laser-television means of trajectory measurements / ISSN 1028-9763. Mathematical
machines and systems , 2017, No.4. P.30-56.

Paper sent: 17.08.2024

© Akhmerov O.Yu.